

D-3 PUMP

Electric Transfer Pump Kit

Features & Benefits

The D-3 Electric Transfer Pump Kit
delivers ready-to-use or diluted seed treatment products to the treater metering tank.

Drive Motor

Powered by a TEFC (Totally Enclosed Fan Cooled) motor, 1/3hp.

Capacity

Pumps from 1-98 gallons per hour, 75 feet vertically, depending upon the viscosity of the product.



Gustafson

 Advanced
Seed Treatment
Technology



A=14" / 36cm
 B=27" / 69cm
 C=13" / 33cm

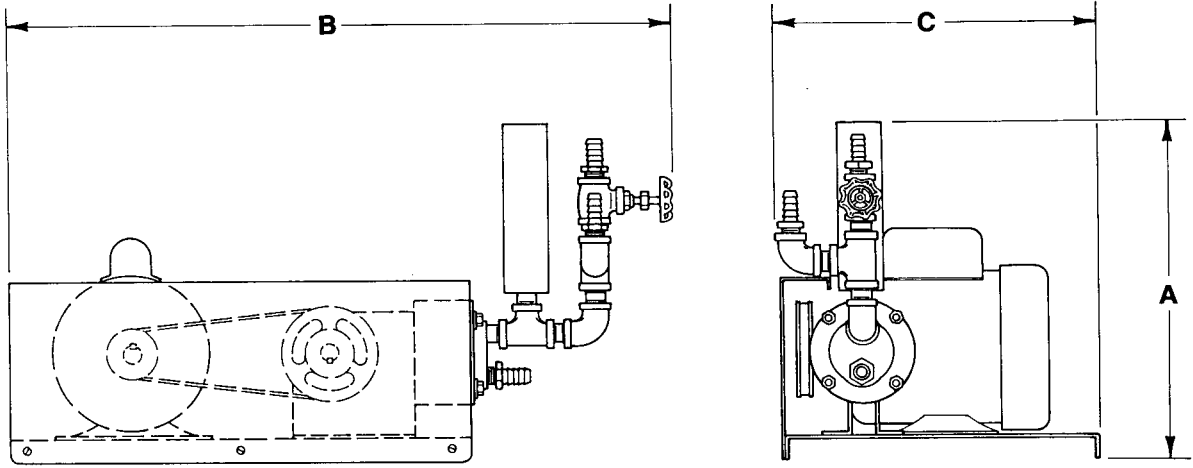

The D-3 Electric Pump Kit for PSD Tanks

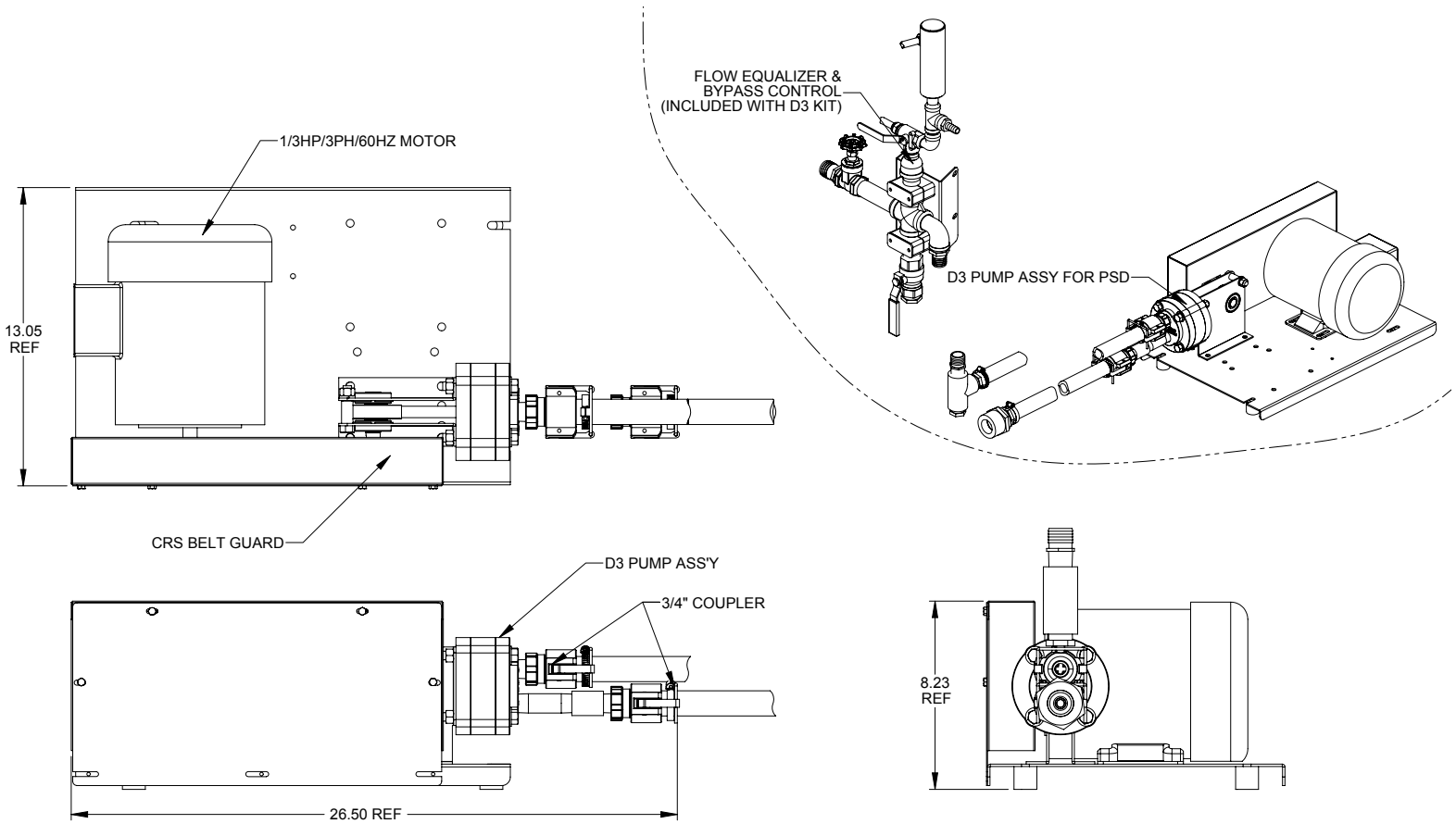

Technical information expressed in this document is for reference purposes only, subject to change without notice. If certified dimensional drawings are required, call 1.800.634.6738.



Bayer CropScience
 4895 12th Avenue East
 Shakopee, Minnesota, 55379
 USA

www.bayercropscienceus.com