

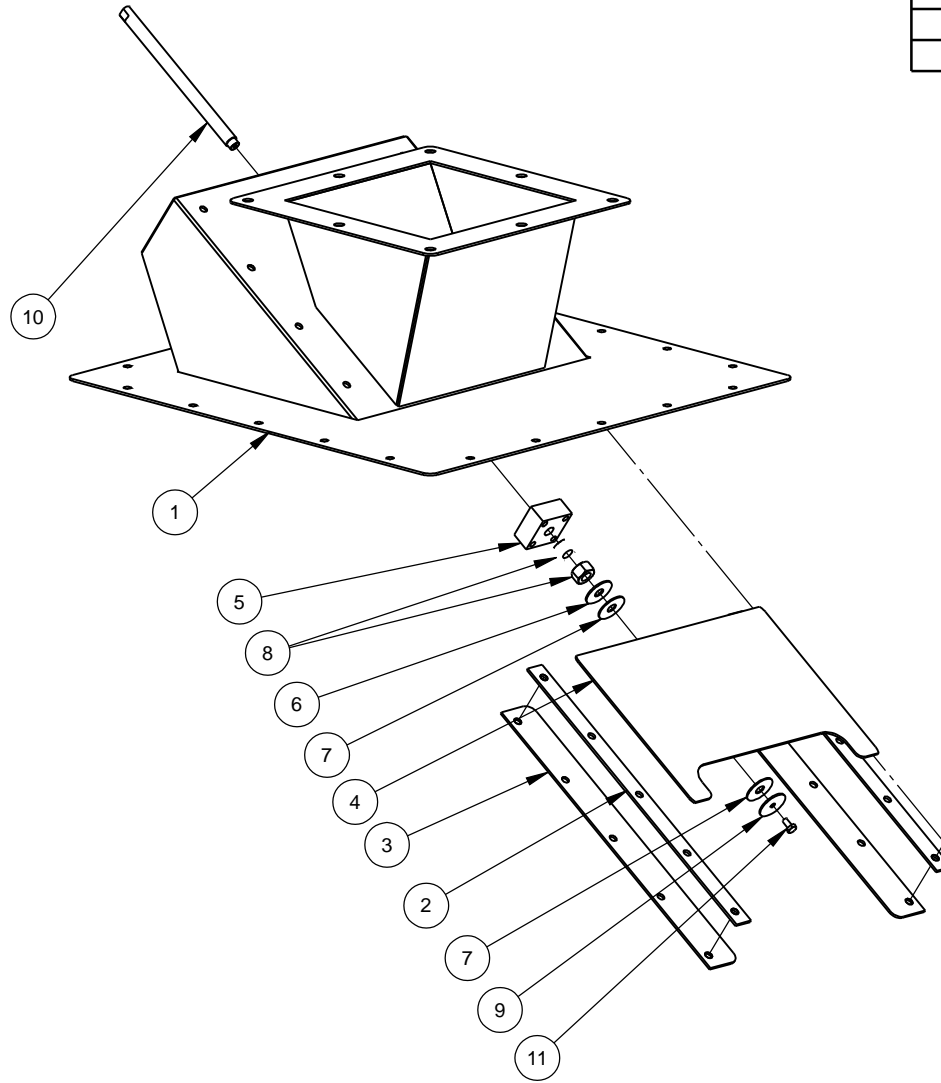

ITEM NO.	PART NUMBER	TITLE	QTY.
1	A247210A	INLET WLDT	1
2	A247228A	SPACER	2
3	A247229A	SPACER	2
4	A247230B	SLIDE WLDT	1
5	A105619A	GUIDE BLOCK	1
6	A105616A	WASHER A	1
7	A105617A	THRUST WASHER	2
8	24750100	5/8-11 HEX NUT SS	2
9	A105618A	WASHER B	1
10	A105656A	ADJUSTO ROD	1
11	17950500	.25-20 x .50 HEX BOLT SS	1

REVISIONS



1 REQ'D / UNIT
BC-150

ASSUMED SYMMETRY OF PARTS IS USED, UNLESS OTHERWISE DIMENSIONED		MFG. APPROVAL XX	DATE 12/14/04	DRAWN BY SAW	DATE 11/10/04	Gustafson  www.gustafson.com	
1 PLACE (X) ± .060" TOLERANCES UNLESS OTHERWISE NOTED 2 PLACE (XX) ± .015" FRACTIONS +1/32" 3 PLACE (XXX) ± .005" FRACTIONS +1/32" 4 PLACE (XXXX) ± .0005" ANGLES ±1/2°		SCALE 1:6	REDRAWN BY -	CHECKED BY SRS	DATE 12/14/04		
TITLE MANUAL INLET ASSY.						PART NUMBER A247430A	REVISION -