

ITEM NO.	PART NO.	TITLE	QTY.
1	A247210A	INLET WLDT	1
2	P000877	1.5 x 7 AIR CYLINDER	1
3	A247228A	SPACER	2
4	A247229A	SPACER	2
5	A247230B	SLIDE WLDT	1
6	.50-13 HEX LOCK NUT SS	.31-18 HEX NUT SS	1
7	P000818	120V/1PH/50-60HZ SOLENOID XP 4-WAY	1
8	87360505	SS SOLENOID BRKT WELDMNT	1
9	80970000	FILTER REGULATOR	1

REVISIONS

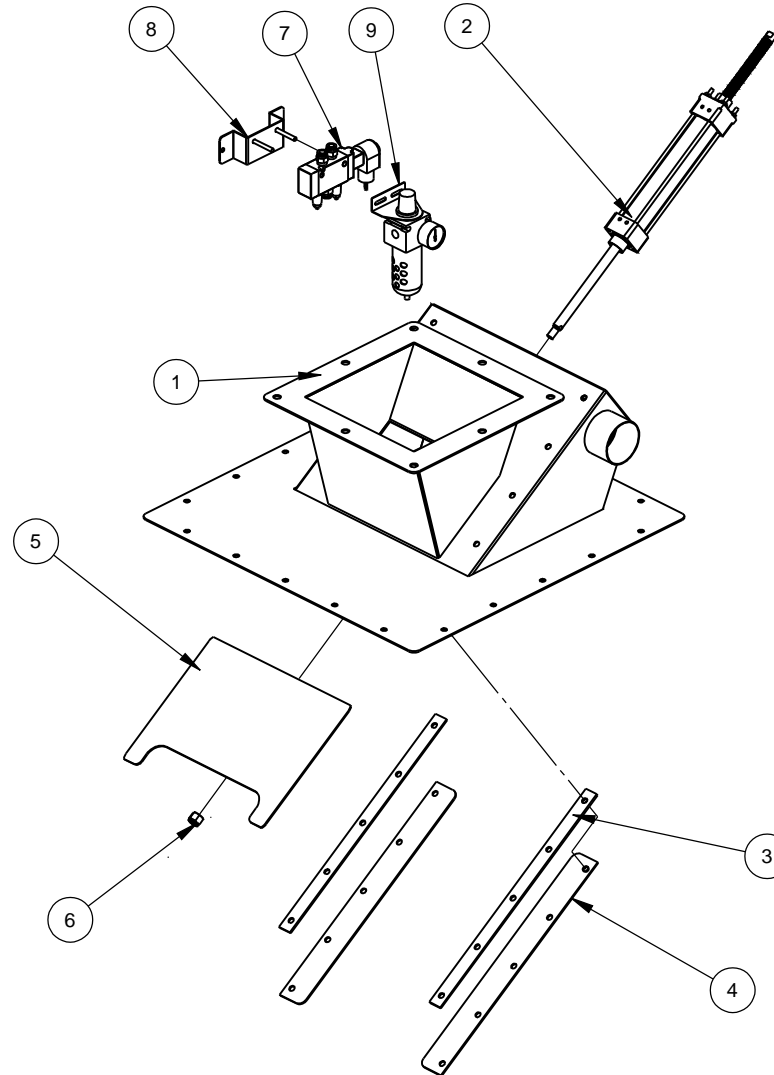
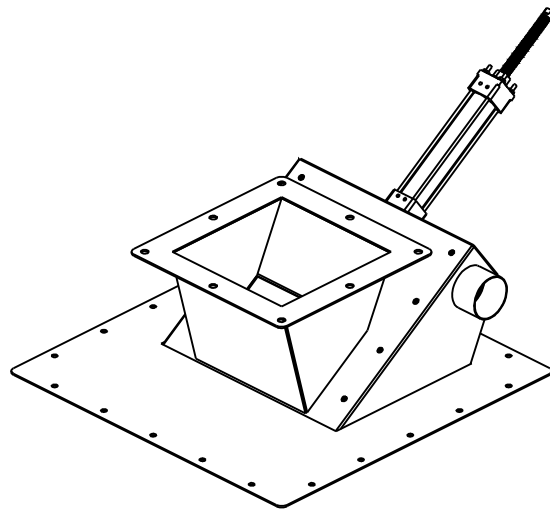

1 REQ'D/ UNIT
BC150

ASSUMED SYMMETRY OF PARTS IS USED, UNLESS OTHERWISE DIMENSIONED	MFG. APPROVAL XX	DATE 11/3/04	DRAWN BY JDB	DATE 8/25/04
1 PLACE (X) ± .060" TOLERANCES UNLESS OTHERWISE NOTED	SCALE 1:8	REDRAWN BY -	CHECKED BY SAW	DATE 11/3/04
2 PLACE (XX) ± .015" FRACTIONS +1/32"	TITLE BC-150 SCALE INLET AUTOMATIC			
3 PLACE (XXX) ± .005" ANGLES ±1/2"	PART NUMBER A247460A			
4 PLACE (XXXX) ± .0005"	REVISION -			

Gustafson 
www.gustafson.com