

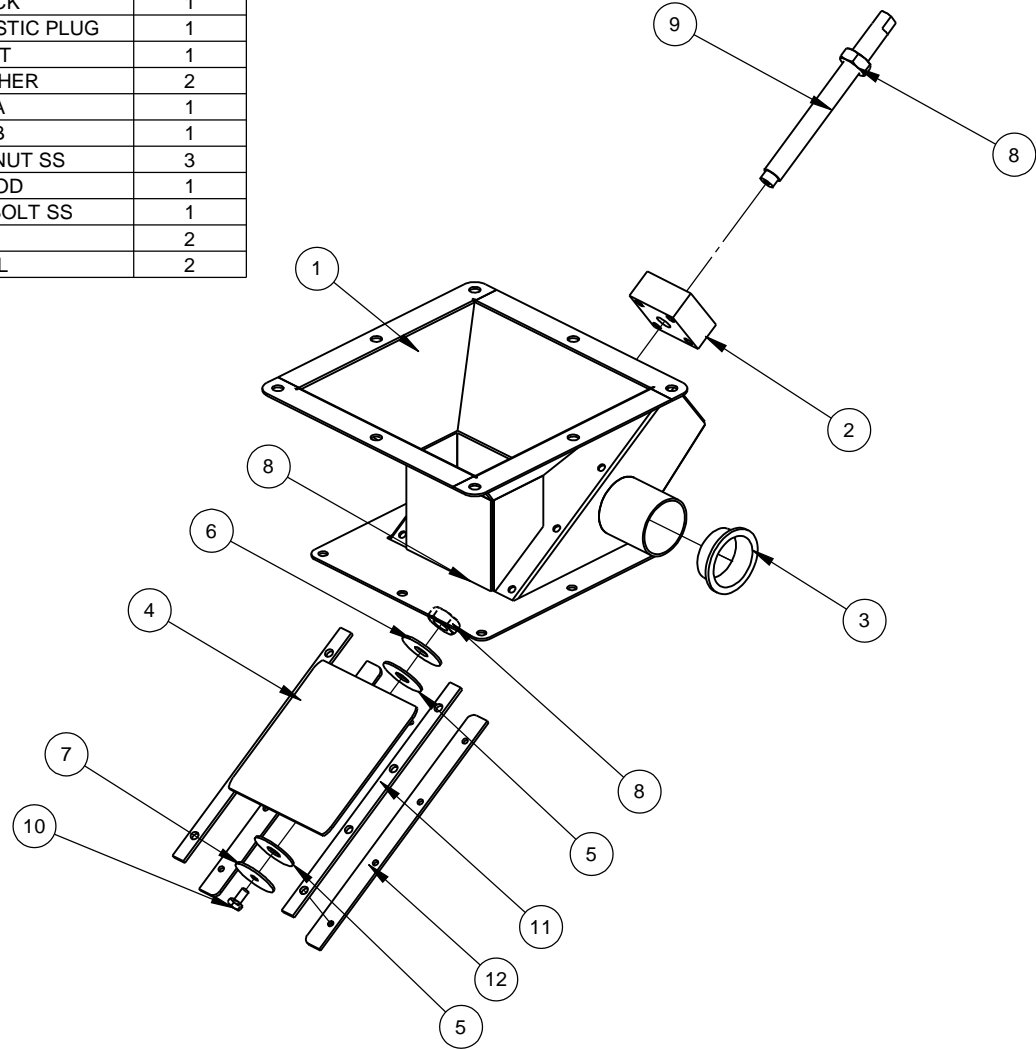

ITEM NO.	PART NUMBER	TITLE	QTY.
1	A355175B	INLET WELDMENT	1
2	A105619A	GUIDE BLOCK	1
3	24370000	1-3/4" FLANGED PLASTIC PLUG	1
4	A355180A	SLIDE WLDT	1
5	A105617A	THRUST WASHER	2
6	A105616A	WASHER A	1
7	A105618A	WASHER B	1
8	P000341	5/8-11 HEX JAM NUT SS	3
9	A105656B	ADJUSTO ROD	1
10	17950500	1/4-20 x .50 HEX BOLT SS	1
11	A355166C	SPACER	2
12	A355167C	GUIDE RAIL	2

REVISIONS



1 REQ'D / UNIT  
BC-5A

ASSUMED SYMMETRY OF PARTS IS USED, UNLESS OTHERWISE DIMENSIONED  1 PLACE (X) ± .060" TOLERANCES- 2 PLACE (XX) ± .015" UNLESS OTHERWISE NOTED 3 PLACE (XXX) ± .005" FRACTIONS 1/32" 4 PLACE (XXXX) ± .0005" ANGLES ± 1/2"	MFG. APPROVAL	DATE	DRAWN BY	DATE	<b>Gustafson</b>  www.gustafson.com
	SCALE	REDRAWN BY	CHECKED BY	DATE	
THIS DRAWING IS GUSTAFSON LLC PROPERTY FOR USE WITH GUSTAFSON LLC EQUIPMENT ONLY. ALL DESIGN AND INVENTION RIGHTS.	TITLE			PART NUMBER	REVISION
	BC-5A SCALE INLET-MANUAL			A355007C	-