

BC SCALES

BC-5A, 50 & 150

Consistent Weighing Scale

Designed to weigh any free-flowing dry material up to 150 tons per hour with accuracy of +/- 1/2%.

Features & Benefits

Pneumatic or manual flow

regulating inlet gate helps even surges from product flow for improved accuracy and overload protection.

Unique flow-through design

allows for a longer "dwell" time and can handle a variety of products and many applications.

Evacuation ports

help improve removal of dust from the weigher.

Internal load cells

relay flow through weight information to the accumulator, ensuring accurate weight information.

Stainless steel construction

for longer machine life and easier clean up.

Factory supplied transition

fits scale to specific application.

Remote Control Box.

Allows integration with an electronic monitoring system.

Flow rate and total indicator

plus 4-20 mA output (32-100° F optimal operating).

Filter regulator with gauge

for air line pressure adjustment and filtration.

Inspection door

with clean-out grate stops over-sized foreign matter from entering the scale.



Gustafson 

 Advanced
Seed Treatment
Technology



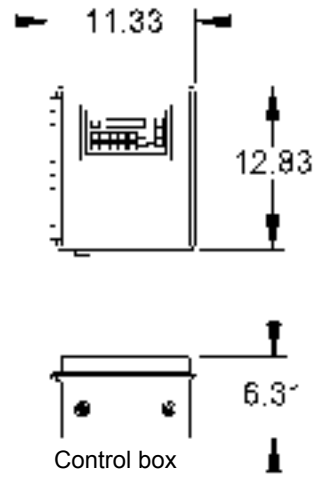
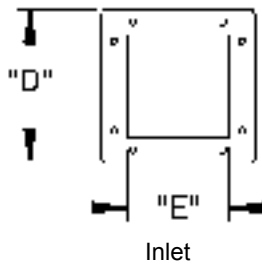
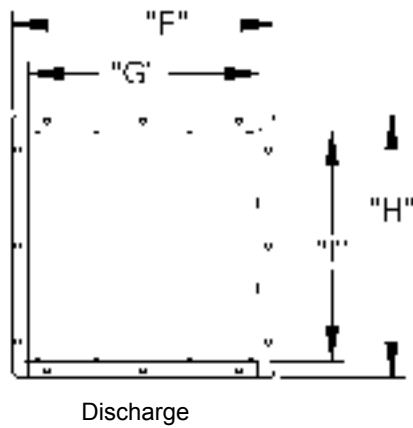
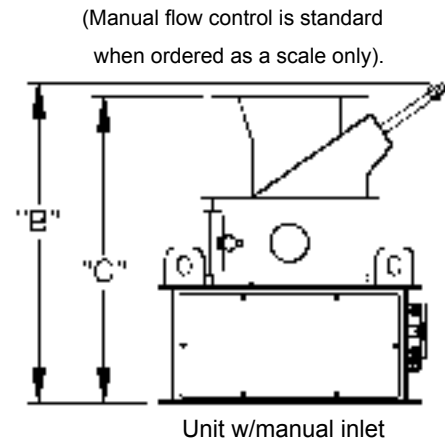
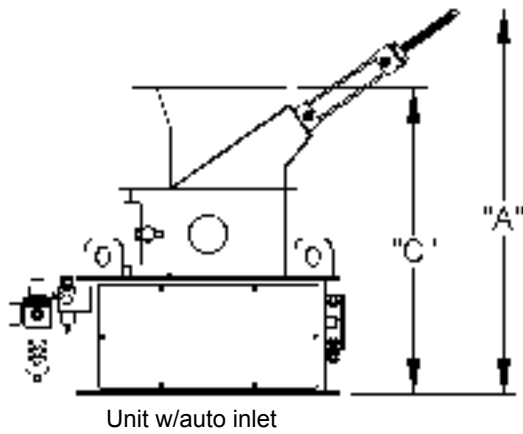

DIMENSIONAL CHART

UNIT	"A"	"B"	"C"	"D" SQ	"E" SQ	"F"	"G"	"H"	"I"
BC 5A	23.36	20.60	19.38	10.00	8.00	15.25	13.25	14.25	12.25
BC 50	30.14	25.01	24.17	12.00	8.00	20.50	18.00	20.50	18.00
BC150	40.21	34.22	32.01	14.00	10.00	30.00	27.00	35.00	32.00

Technical information expressed in this document is for reference purposes only, subject to change without notice. If certified dimensional drawings are required, call 1.800.634.6738.



Bayer CropScience



Bayer CropScience
 4895 12th Avenue East
 Shakopee, Minnesota, 55379
 USA

www.bayercropscienceus.com