

RH 2000 Commercial 48" Seed Treating System

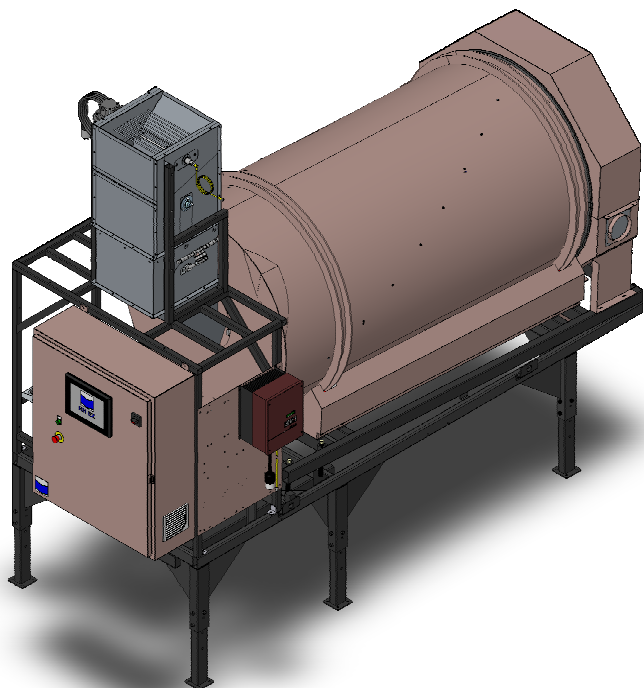

Recommended for treating Corn, Cotton, Rice, Sugar Beet, Sorghum, Soybean and Wheat seed



Features & Benefits

- Automatic pump speed compensation helps prevent over/under treatment.
- Rotary volumetric seed wheel provides positive control of seed delivery and precise seed calibration
- MIST-O-MATIC® atomizer for improved treatment-to-seed coverage, does not require any lubrication
- UL 508 Listed control panel provides easy recipe creation and controls up to four pumps simultaneously or individually
- State of the art electronics 12" color touch screen HMI interface and highly accurate AC variable frequency drives
- PLC features data and reporting output capabilities (printer not included)
- Variable speed drum control provides maximum blending efficiency and easily accommodates different seed types
- Corrosion resistant stainless steel treating head helps ensure long life and abrasion resistance
- Adjustable stand accommodates conveyor hoppers and height imitations
- Drum lift bar design helps ensure homogenous treatment-to-seed coverage. Lift bar design, combined with drum speed control, provides gentle tumbling and reduces seed damage
- Optional Inlet surge bin
- Optional inlet conveyor control for automating conveyors. Includes hi/lo sensors. Compatible with most automated system controls

Value Added Services

- Includes start-up, installation and training
- Site assessments
- CAD drawings for site planning
- Annual software upgrade
- Distributor network
- National service support
- RH seed treating systems are compliant with all seed company specifications and requirements.

Capacity

- 2700 u/hr (unit=50lb) based on soybeans

Treater Dimensions: Height 123.79" (adjustable) Length 128.18" width 50.00"



Rotary Volumetric Seed Wheel

Precise calibration and positive seed delivery control

- Rotary seed wheel connected to control box
- High quality stainless steel construction
- Connected to commercial grade AC and gear motors
- True 2,700 units per hour (unit = 50lb.)
- Upgrade current HC models with new RH seed wheel
- Safety guard above the seed wheel
- Safe and gentle seed handling
- Seed sensor - when no seed is available, system will shut down



Closed Calibration Tank & Pump System

New Top Mount 100oz Closed Calibration

- Provides accurate real time calibration by volume
- Peristaltic pump equipped with various element sizes
- Chemical recirculation function
- Quick disconnect NPT fittings for easy cleaning
- Tank agitation - for continuous chemical suspension
- When seed wheel stops, the pump stops
- Closed calibration limits worker exposure for improved safe handling procedures



Flow Meter

- Helps prevent costly spills due to hose malfunction
- Flow meter communicates with the PLC
- Easy cleaning and maintenance
- Cost effective and quality design

Drum & Frame Features

- Direct drum drive
- Soft start/stop for full drum
- Drum angle adjustment
- Adjustable frame height
- Reversible drum for clean out
- Variable speed drum drive
- Adjustable drum and frame accommodates unique seed flow changes

Guide to responsible Seed Treatment

BEFORE APPLICATION		DURING APPLICATION	
1	Use only high quality products specially designed and approved for seed treatment	7	Mix products properly according to the label; mix each product well with the water in the tank before adding the next product
2	Keep the products in a locked room that is approved for crop protection products	8	Avoid spillage. Thoroughly clean any spillage to avoid contaminating the environment and waterways
3	Read the label and the directions for use carefully before using the product, especially the safety requirements	9	Rinse the empty containers three times, pour the rinse water into the mixing tank and recycle the containers
4	Protect yourself effectively - use gloves, glasses, mask, overalls, boots - as appropriate and according to each product label	AFTER APPLICATION	
5	Regularly check, maintain and adjust the seed treatment equipment to ensure accurate application	10	Ensure that access to treated seeds is not possible for children, the public or domestic animals
6	Treat only well cleaned seed to avoid contamination of yourself and the equipment by contaminated dust	11	Avoid contamination of your hands when handling treated seeds
		12	Clean the protection equipment. Wash your hands. Take a shower

Advanced Seed Treatment Bayer CropScience



Bayer CropScience

Bayer CropScience LP
 4895 12th Avenue East
 Shakopee, Minnesota - USA
www.bayercropscience.us
 Phone: +1 952 445 6868
 Toll Free: 1 800 634 6738
 E-mail: equipment@bayer.com

Before using any crop protection product you should read and carefully follow directions, cautionary statements, and other information appearing on the product label. Our technical information is based on extensive testing and is, to the best of our current knowledge, true and accurate but given without warranty as the conditions of use and storage are beyond our control. Descriptions and property data of the product do not contain any statement as to liability for possible damage.

BCSRH2000COMMERCIAL4806282011